

VELIA EX

0PBM10P & 0PBH12PH Series

MID AND HIGH LEVEL ORDER PICKERS

1.0 - 1.25 tonnes

SCALE THE HEIGHTS OF PRODUCTIVITY

At Mitsubishi Forklift Trucks, our designers love a challenge. And, as any warehouse manager knows, there's no greater challenge than order picking. Every second counts in this labour-intensive task. The result? VELiA EX. This high-efficiency range of mid and high-level order pickers has been engineered to scale the heights of productivity.

SPECIFICATIONS

0PBM10P
0PBH12PH



WHEN
RELIABILITY IS
EVERYTHING...

VELiA EX

OPBM10P & OPBH12PH Series

MID AND HIGH LEVEL ORDER PICKERS

1.0 – 1.25 tonnes



Exceptionally high visibility? Yes, thanks to our MaxVision mast and clearview overhead guard. Ultimate reliability? Yes. With our VELiA EX mid and high-level order pickers – including a high-performance 48 V model with unbeatable 1250 kg capacity, you can expect practically perfect picking.

Outstanding comfort features? Of course. Like every Mitsubishi order picker, it's got those crucial differences which never fail to impress operators (or their employers).

FRAME AND BODY

- **Chillproof design with rust-proof axles**
ensures reliable performance at temperatures as low as 0°C.
- **MaxVision mast and overhead guard**
maximises operator field of vision for increased productivity and safety.
- **Robust construction**
ensures smooth, stable ride and excellent picking performance.
- **Low maintenance design**
gives quick and easy access to key components and motors – for minimum downtime.

DRIVE

- **Powerful AC motor**
means high drive speed and acceleration – even when loaded – plus smooth, quiet, controlled operation, extended shift length and lower maintenance requirements.
- **ECO mode**
reduces energy consumption – without compromising on performance.

- **Smart curve control**
automatically reduces speed when cornering for enhanced stability.

ELECTRICAL CONTROL SYSTEMS

- **Performance setting**
– including pre-set modes – allows instant programming without special tools.
- **On-board diagnostics and fault memory folder**
keep operator and service engineer aware of any problems, speed up servicing and help prevent damage.

OPERATOR ENVIRONMENT & CONTROLS

- **Ultra-low step height (just 215 mm) offers**
easy on/off access to keep operators alert and productive throughout shifts.
- **Easy-access operator's compartment**
is spacious and features an extra-wide entry for faster mounting and dismantling.
- **High-visibility cabin**
features see-through panels for maximum forward views – reducing damage risk, while increasing operator comfort and efficiency.
- **Operator Presence Sensor**
covers a wide area and eliminates need for dead man's switch (and associated risks).
- **Super-grip floor**
is non-slip ensuring operators are safe, for confident operations.
- **PIN-code access**
for up to 100 users is possible – preventing unauthorised use.

- **Easy-grip handles**
ensure safe and easy entry and exit from spacious platform.
- **Battery discharge indicator**
keeps operators aware of battery discharge levels – ensuring high-efficiency operations and long battery life.
- **MaxPro side-access gates with automatic sensors**
prevent unsafe use of truck with gates open at heights above 1200 mm.
- **Easy-access storage compartments**
ensure pickers have everything they need to work productively within easy reach.
- **Fully adjustable ergonomic seat**
provides a comfortable seat or cushion to lean on during long journeys – minimising risk of fatigue.

OTHER FEATURES

- **Rapid battery access**
reduces time needed for daily checks for maximum uptime.
- **Warning lights**
fitted on straddle legs and chassis alert vehicle and on-foot traffic – for enhanced safety.
- **Hydraulic and drive interlock**
prevents truck use while operator isn't present.

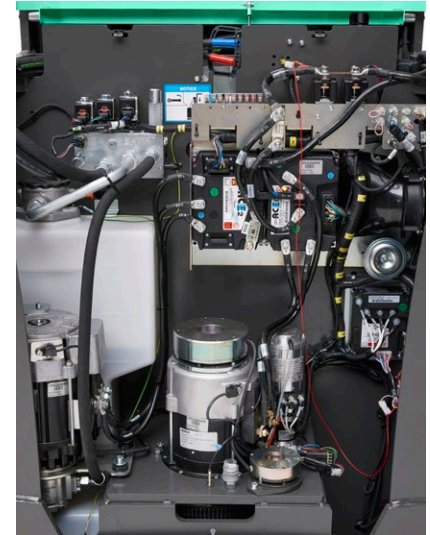
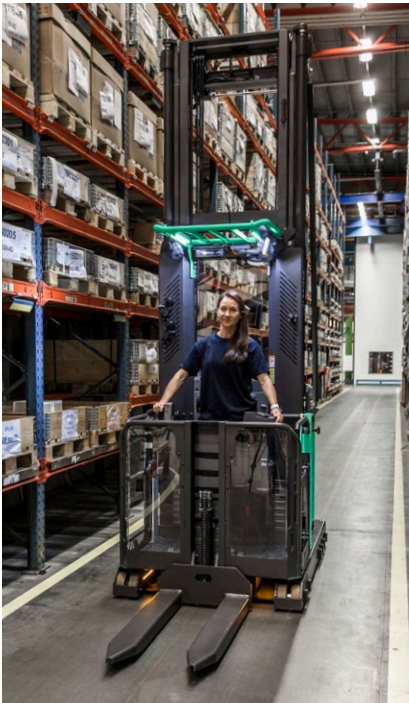

There is more information on VELiA EX on mitforklift.com

For more extensive information please visit our website mitforklift.com



VDI - PERFORMANCE & DIMENSIONS

CHARACTERISTICS				Mitsubishi Forklift Trucks	Mitsubishi Forklift Trucks
1.1	Manufacturer			OPBM10P DUPLEX	OPBM10P TRIPLEX FREE LIFT
1.2	Manufacturer's model designation			Battery	Battery
1.3	Power source: (battery, diesel, LP gas, petrol)			Stand-on	Stand-on
1.4	Operator type: pedestrian, (operator)-standing, -seated				
1.5	Load capacity	Q	kg	1000	1000
1.6	Load center distance	c	mm	600	600
1.8	Load wheel axle to fork face (forks lowered)	x	mm	125	204
1.9	Wheelbase	y	mm	1568	1568
WEIGHT					
2.1b	Truck weight without load, with maximum battery weight		kg	2050 + (96 x h12) ³⁾	2260 + (91.5 x h12) ³⁾
2.2	Axle loadings with nominal load & maximum battery weight, drive/load side		kg	1110 / 2800	1210 / 2910
2.3	Axle loadings without load & with maximum battery weight, drive/load side		kg	1660 / 1250	1790 / 1330
WHEELS, DRIVE TRAIN					
3.1	Tyres: PT=Power Thane, Vul=Vulkollan, drive/load side			Vul / Vul	Vul / Vul
3.2	Tyre dimensions, drive side		mm	250 x105	250 x105
3.3	Tyre dimensions, load side		mm	150 x 55	150 x 55
3.5	Number of wheels, load/drive side (x=driven)			8 / 1x	8 / 1x
3.7	Track width (center of tyres), load side	b11	mm	806 / 906 / 1006	906 / 1006
DIMENSIONS					
4.2a	Height with mast lowered	h1	mm	h12 / 2 + 592	h12 / 3 + 637
4.4	Lift height (without h9)	h3	mm	3285 - 7185	4885 - 8035
4.5	Height with mast extended	h4	mm	h12 + 2140	h12 + 2160
4.7	Height to top of overhead guard	h6	mm	2356	2356
4.8	Seat- or stand height	h7	mm	215 - h12	215 - h12
4.10	Height of support legs	h8	mm	175	175
4.11	Supplementary lift	h9	mm	775	775
4.14	Platform height, raised	h12	mm	3600-7400	5200-8250
4.15	Fork height, fully lowered	h13	mm	90	90
4.19	Overall length	l1	mm	3055	3135
4.20	Length to fork face	l2	mm	1903	1982
4.21	Overall width	b1	mm	970 / 1070 / 1170	1070 / 1170
4.22	Fork dimensions (thickness, width, length)	s/e/l	mm	70 / 147 / 1150	70 / 147 / 1150
4.24	Fork carriage width	b3	mm	560	560
4.25	Outside width over forks (minimum-maximum)	b5	mm	450 - 800	450 - 800
4.27	Width over guide rollers (minimum-maximum)	b6	mm	1148 - 1814	1248 - 1814
4.32	Ground clearance at center of wheelbase, (forks lowered)	m2	mm	25	25
4.33a	Working aisle width (Ast) with 1000 x 1200 mm pallets, load crosswise	Ast	mm	Platform or load width + clearance	Platform or load width + clearance
4.34a	Working aisle width (Ast) with 800 x 1200 mm pallets, load lengthwise	Ast	mm	Platform or load width + clearance	Platform or load width + clearance
4.35	Turning radius	Wa	mm	1790	1790
4.41	Transfer aisle width (pallet 1000 x 1200 mm lengthwise & 200 mm clearance)	Au	mm	3265	3336
PERFORMANCE					
5.1	Travel speed, with/without load		km/h	11 / 11	11 / 11
5.2	Lifting speed, with/without load		m/s	0.21 / 0.32	0.26 / 0.37
5.3	Lowering speed, with/without load		m/s	0.4 / 0.4	0.41 / 0.42
5.8	Maximum gradeability, with/without load		%	7.1	7.1
5.9	Acceleration time (10 metres) with/without load		s	6.3 / 5.8	6.3 / 5.8
5.10	Service brake			Electric	Electric
ELECTRIC MOTORS					
6.1	Drive motor capacity (60 min. short duty)		kW	2.7	2.7
6.2	Lift motor output at 15% duty factor		kW	8 (20%)	8 (20%)
6.3	Battery to DIN 43 531/35/36 A/B/C/no			BS	BS
6.4	Battery voltage/capacity at 5-hour discharge		V/Ah	24 / 560 - 775	24 / 560 - 775
6.5	Battery weight		kg	500 - 700	500 - 700
MISCELLANEOUS					
8.1	Type of drive control			Stepless	Stepless
10.7	Level of noise at the ear level of the driver according to EN 12 053:2001 and EN ISO 4871 in work LpAZ		dB(A)	66	66

3) Use h12 dimension in metres for calculation. This is the extra weight in the mast per metre of lift height.

VELIA EX

OPBM10P Series MID LEVEL ORDER PICKERS

1.0 tonnes

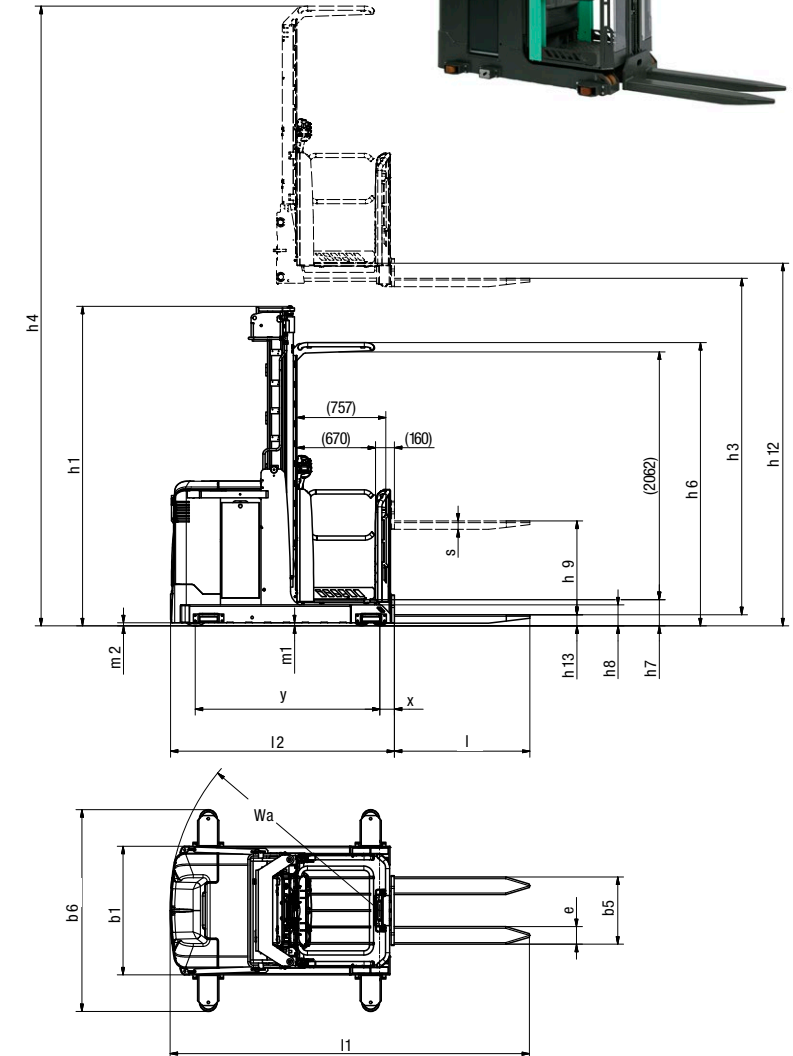

VDI - PERFORMANCE & DIMENSIONS

CHARACTERISTICS			
1.1	Manufacturer		Mitsubishi Forklift Trucks
1.2	Manufacturer's model designation		OPBH12PH
1.3	Power source: (battery, diesel, LP gas, petrol)		Battery
1.4	Operator type: pedestrian, (operator)-standing, -seated		Stand-on
1.5	Load capacity	Q	kg
1.6	Load center distance	c	mm
1.8	Load wheel axle to fork face (forks lowered)	x	mm
1.9	Wheelbase	y	mm
WEIGHT			
2.1b	Truck weight without load, with maximum battery weight		kg
2.2	Axle loadings with nominal load & maximum battery weight, drive/load side		kg
2.3	Axle loadings without load & with maximum battery weight, drive/load side		kg
WHEELS, DRIVE TRAIN			
3.1	Tyres: PT=Power Thane, Vul=Vulkollan, drive/load side		Vul / Vul
3.2	Tyre dimensions, drive side		mm
3.3	Tyre dimensions, load side		mm
3.5	Number of wheels, load/drive side (x=driven)		
3.7	Track width (center of tyres), load side	b11	mm
DIMENSIONS			
4.2a	Height with mast lowered	h1	mm
4.4	Lift height (without h9)	h3	mm
4.5	Height with mast extended	h4	mm
4.7	Height to top of overhead guard	h6	mm
4.8	Seat- or stand height	h7	mm
4.10	Height of support legs	h8	mm
4.11	Supplementary lift	h9	mm
4.14	Platform height, raised	h12	mm
4.15	Fork height, fully lowered	h13	mm
4.19	Overall length	l1	mm
4.20	Length to fork face	l2	mm
4.21	Overall width	b1	mm
4.22	Fork dimensions (thickness, width, length)	s/e/l	mm
4.24	Fork carriage width	b3	mm
4.25	Outside width over forks (minimum-maximum)	b5	mm
4.27	Width over guide rollers (minimum-maximum)	b6	mm
4.32	Ground clearance at center of wheelbase, (forks lowered)	m2	mm
4.33a	Working aisle width (Ast) with 1000 x 1200 mm pallets, load crosswise	Ast	mm
4.34a	Working aisle width (Ast) with 800 x 1200 mm pallets, load lengthwise	Ast	mm
4.35	Turning radius	Wa	mm
4.41	Transfer aisle width (pallet 1000 x 1200 mm lengthwise & 200 mm clearance)	Au	mm
PERFORMANCE			
5.1	Travel speed, with/without load	km/h	12 / 12
5.2	Lifting speed, with/without load	m/s	0.36 / 0.44
5.3	Lowering speed, with/without load	m/s	0.46 / 0.45
5.8	Maximum gradeability, with/without load	%	6.2
5.9	Acceleration time (10 metres) with/without load	s	5.5 / 5.2
5.10	Service brake		Electric
ELECTRIC MOTORS			
6.1	Drive motor capacity (60 min. short duty)	kW	5.9
6.2	Lift motor output at 15% duty factor	kW	11
6.3	Battery to DIN 43 531/35/36 A/B/C/no		DIN 43531 B
6.4	Battery voltage/capacity at 5-hour discharge	V/Ah	48 / 500 - 620
6.5	Battery weight	kg	890 - 1125
MISCELLANEOUS			
8.1	Type of drive control		Stepless
10.7	Level of noise at the ear level of the driver according to EN 12 053:2001 and EN ISO 4871 in work LpAZ	dB(A)	65

3) Use h12 dimension in metres for calculation. This is the extra weight in the mast per metre of lift height.

VELIA EX

OPBH12PH Series HIGH LEVEL ORDER PICKERS

1.25 tonnes

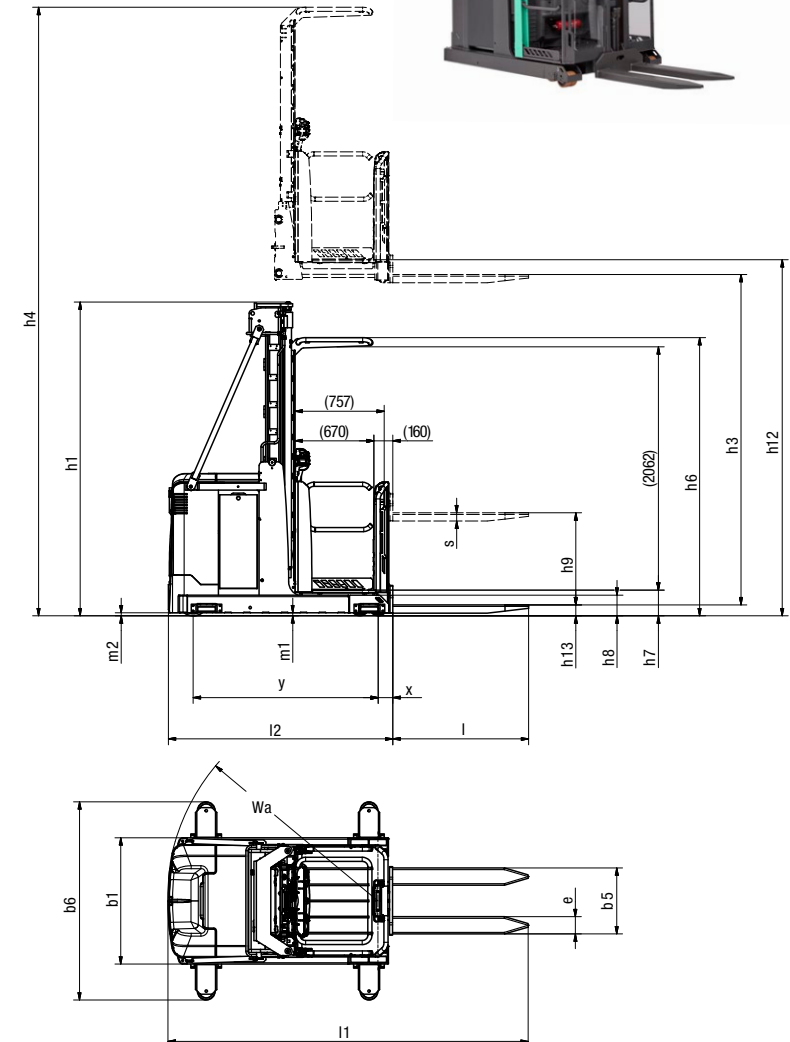

MAST PERFORMANCE AND CAPACITY



OPBM10P Series

OPBM10P				mL ≤ 25 mm	mL ≤ 25 mm	mL ≤ 25 mm
MAST TYPE	h12 mm	h1 mm	h = h12-125+775 mm	b1 = 970	b1 = 1070	b1 = 1170
	Platform floor height	Closed mast height	Fork height EasyLift raised	Q @ c = 400-600mm kg	Q @ c = 400-600mm kg	Q @ c = 400-600mm kg
DUPLIX	3600	2392	4250	1000	1000	1000
	4000	2592	4650	1000	1000	1000
	4400	2792	5050	1000	1000	1000
	4700	2942	5350	1000	1000	1000
	5000	3092	5650	1000	1000	1000
	5400	3292	6050	1000	1000	1000
	5800	3492	6450	-	1000	1000
	6200	3692	6850	-	1000	1000
	6600	3892	7250	-	-	1000
	7000	4092	7650	-	-	800
7400	4292	8050	-	-	650	
TRIPLEX FREE-LIFT	5200	2370	5850	N/A	1000	1000
	5500	2470	6150	N/A	1000	1000
	6100	2670	6750	N/A	1000	1000
	6550	2820	7200	N/A	-	1000
	7000	2970	7650	N/A	-	800
	7800	3237	8450	N/A	-	650
8250	3387	8900	N/A	-	600	

Load deration based on load evenly spread along the forks
 Load deration on request when LC >600 mm
 mL = is ground clearance

Standard lift heights are limited by truck width.
 Therefore residual capacity is shown at maximum standard lift height for the relative truck width.

Other higher options may be available but subject to special design.

- h1 Closed mast height
- h12 Lift height
- h Fork height EasyLift raised
- b1 Chassis width
- Q Lifting capacity, rated load
- c Load centre distance

OPBH12PH Series

OPBH12PH				mL ≤ 15 mm	mL ≤ 15 mm
MAST TYPE	h12 mm	h1 mm	h = h12-125+775 mm	b1 = 1170	b1 = 1350
	Platform floor height	Closed mast height	Fork height EasyLift raised	Q @ c = 400-600mm kg	Q @ c = 400-600mm kg
TRIPLEX FREE-LIFT	6000	2770	6650	1250	1250
	6750	3020	7400	1250	1250
	7500	3270	8150	1250	1250
	(7750)	3353	8400	1100	1250
	8250	3520	8900	900	1250
	(8500)	3603	9150	850	1250
	9000	3770	9650	750	1250
	9750	4020	10400	-	1100
	(10000)	4103	10650	-	1000
	10500	4270	11150	-	900

() = Non standard mast, only to show capacity
 Load deration based on load evenly spread along the forks
 Load deration on request when LC >600 mm
 mL = is ground clearance

Standard lift heights are limited by truck width.
 Therefore residual capacity is shown at maximum standard lift height for the relative truck width.

Other higher options may be available but subject to special design.

All capacities are based on VNA standard floors where ground clearance is not greater than 15 mm.
 If adjustable lugs are altered to be greater than 15mm then capacity will be reduced.

STANDARD EQUIPMENT & OPTIONS

- = Standard
- = Option

	OPBM10P	OPBH12PH
GENERAL		
Micro-computer incl. Hour meter and battery indicator	●	●
PIN code log in, 100 codes	●	●
Key switch entry	●	●
Display incl. Steering wheel indicator	●	●
Drive and lift controls on mast side	●	●
Operators presence sensor in floor	●	●
Cornering control	●	●
Two hand operation in guided aisles	●	●
Platform with Ergolift and fixed forks	●	●
Pro Access gates	●	●
Warning light	●	●
GUIDANCE		
Rail guidance	●	●
Wire guidance	●	●
DESCENDER DEVICE		
Descender device	●	●
High specification escape device	●	●
ENVIRONMENT		
Chill store design, with rust protected axles	●	●
Cold store design, 0C° to -35C°	●	●
DRIVE, LIFT CONTROLS		
On fork side	●	●
On fork and mast side	●	●
Extra buttons for ergolift (mast side)	●	●
COMPUTER EQUIPMENT		
Automatic log off	●	●
Service alarm	●	●
Battery creep speed	●	●
DRIVE AND LIFT STOP		
Drive stop	●	●
Lift stop with/without restart	●	●
SAFETY		
Finger guards toward mast	●	●
Gate interlock, <1200 mm platform height	●	●
Gate open audible warning, >415 mm platform lift	●	●
Prepared for Personal Protection System, PPS	●	●
End of aisle reduced speed options	●	●
OTHER		
Mini steering wheel	●	●
Light in cabin, for racks	●	●
Light in cabin, for interior	●	●
Radio with MP3	●	●
Converter 24-12 V, 8 A, 96 W outlet	●	●
12V DC power socket, Cigarette power outlet	●	●
Equipment holder, RAM system, Size C	●	●
Foldable driver's cushion	●	●
Comfort fan for driver	●	●
Extra storage in platform	●	●
Fire extinguisher	●	●

VELIA EX

OPBM10P & OPBH12PH Series MID AND HIGH LEVEL ORDER PICKERS

1.0 – 1.2 tonnes



Optional folding driver's cushion



Clear warning light



Easy access

WHEN RELIABILITY IS EVERYTHING...



VELIA
THE FRONT RUNNER

When developing the award-winning VELiA family of low, mid and high level order pickers, our primary aim was to deliver exceptional productivity through unrivalled ergonomics and driveability.

Like any product bearing the "MITSUBISHI" name our materials handling equipment benefits from the tremendous heritage, huge resources and cutting-edge technology of one of the world's largest corporations – Mitsubishi Heavy Industries Group.

Engineering spacecraft, jet planes, power plants and more, MHI specialises in those technologies where performance, dependability and superiority decide your success or failure...

So when we promise you quality, reliability and value for money, you know it's a guarantee we have the power to deliver.

That's why every model in our award-winning and comprehensive range of lift trucks and warehouse equipment is built to a high specification – to ensure it keeps working for you. Day after day. Year after year. Whatever the job. Whatever the conditions.

YOU'LL NEVER WORK ALONE

As your local authorised dealer, we are here to keep your trucks working – through our extensive experience, our technical excellence and our commitment to customer care.

We are your local experts, backed by efficient channels to the entire organisation of Mitsubishi Forklift Trucks.

No matter where you are, we are close by – with the capability to meet your needs.

Discover how Mitsubishi Forklift Trucks give you more from your local authorised dealer or when you visit our website www.mitforklift.com

Performance specifications may vary depending on standard manufacturing tolerances, vehicle condition, types of tyres, floor or surface conditions, applications or operating environment. Trucks may be shown with non-standard options. Specific performance requirements and locally available configurations should be discussed with your distributor of Mitsubishi forklift trucks. We follow a policy of continual product improvement. For this reason, some materials, options and specifications could change without notice.

info@mitforklift.com

WESM2111 (01/21) © 2021 MLE

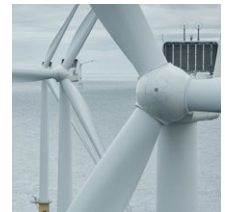

Mitsubishi Logisnext Europe B.V.
Hefbrugweg 77, 1332 AM Almere
The Netherlands
Tel: +31 (0)36 5494 411



mft2.eu/fb



mft2.eu/apps



mft2.eu/youtube



mft2.eu/facebook

